

.....
BACHELOR OF TECHNOLOGY (C.B.C.S.) (2014 COURSE)
B.Tech.Sem - VI MECHANICAL : WINTER- 2022
SUBJECT : RELIABILITY ENGINEERING

Day : Wednesday

Time : 10:00 AM-01:00 PM

Date : 30-11-2022

W-13456-2022

Max. Marks : 60

N.B.

- 1) All questions are **COMPULSORY**.
 - 2) Figures to the right indicate **FULL** marks.
 - 3) Draw neat and labelled diagram **WHEREVER** necessary
 - 4) Use of non – programmable **CALCULATOR** is allowed.
 - 5) Use suitable data **WHEREVER** necessary.
-

Q.1 Explain the term MTTF, MTBF and Failure density (fd) (10)

OR

Following table shows the tests results for 100 components tested

Operating Time (Hrs.)	0	10	20	30	40	50	60	70	80	90	100
No. of surviving components	100	94	80	75	66	60	50	48	45	40	35

Evaluate: Hazard rate, failure density function and reliability. Plot these functions against time.

Q.2 The failure time of mechanical components follows Weibull distribution with $\beta = 3$, $\eta = 2500$, $l = 1000$, Find the reliability by component and the failure rate for an operating time of 2000 hours. (10)

OR

Define standard deviation and variance. Explain the difference between a discrete and a continuous random variable. Give two example of each.

Q.3 It is observed that the failure pattern of an electronic system follows an exponential distribution with mean time to failure of 1000 hours, what is probability that the system failure occurs within 750 hours? (10)

OR

What are series parallel and parallel series systems? What is meant by complex system? List three methods for finding the reliability of complex system.

Q.4 The following data refer to predicted reliability of six components in series. (10)
In case the desired reliability of the system is not fall below 0.85. Find the reliability goal for individual components.

Components	1	2	3	4	5	6
Predicted Reliability	0.994	0.998	0.990	0.996	0.990	0.980

OR

Explain availability and its types. If an inherent availability 0.9 is mean and MTBF is 200 hours. What is maximum possible MTTR?

P.T.O.

Q.5 Write short note on following

(10)

- i) Symbols for Fault Tree construction
- ii) Steps in FMEA
- iii) Risk Priority Number (RPN)

OR

Determine the reliability of the system shown in fig. by using minimal Tie set and minimal cut set method.

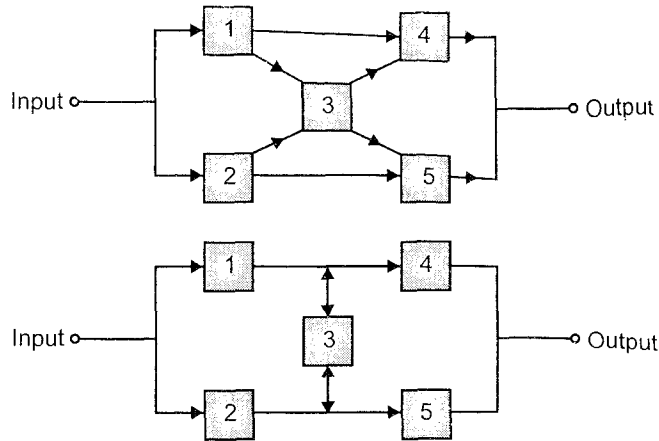

Q.6 Explain briefly the various methods of assessing reliability of a component through accelerated test. (10)

OR

Explain the markov model. How it is applied in reliability analysis of a system having constant hazard rate?

*

*

*