

BACHELOR OF TECHNOLOGY (C.B.C.S.) (2014 COURSE)
B.Tech.Sem - V MECHANICAL MECHANICAL :SUMMER- 2022
SUBJECT : ADVANCED MANUFACTURING PROCESSES

Day : Friday
 Date : 3/6/2022

S-13449-2022

Time : 10:00 AM-01:00 PM
 Max. Marks : 60

N.B:

- 1) All questions are **COMPULSORY**.
- 2) Figures to the **RIGHT** indicate full marks.
- 3) Use of non programmable **CALCULATOR** is allowed.
- 4) Assume suitable data if necessary.

- Q.1 a)** What is mean by percentage penetration? Sketch the various methods of applying shear to the punch and die. (05)
- b)** A waster with 15 mm internal hole outside diameter 24 mm is to be made from 1.8mm thick strip. Find clearance, blanking and die opening size, blanking punch size, piercing punch size and piercing die opening size (one side clearance 8% of t) (05)

OR

- a)** Write down advantages and limitation of sheet metal working processes. (05)
- b)** Explain methods of reducing cutting forces in a piercing operation. (05)
- Q.2** Design and draw a jig suitable for drilling four though holes parallel to the axis of a no. of pre-machined aluminum disc as shown in fig.1. (10)

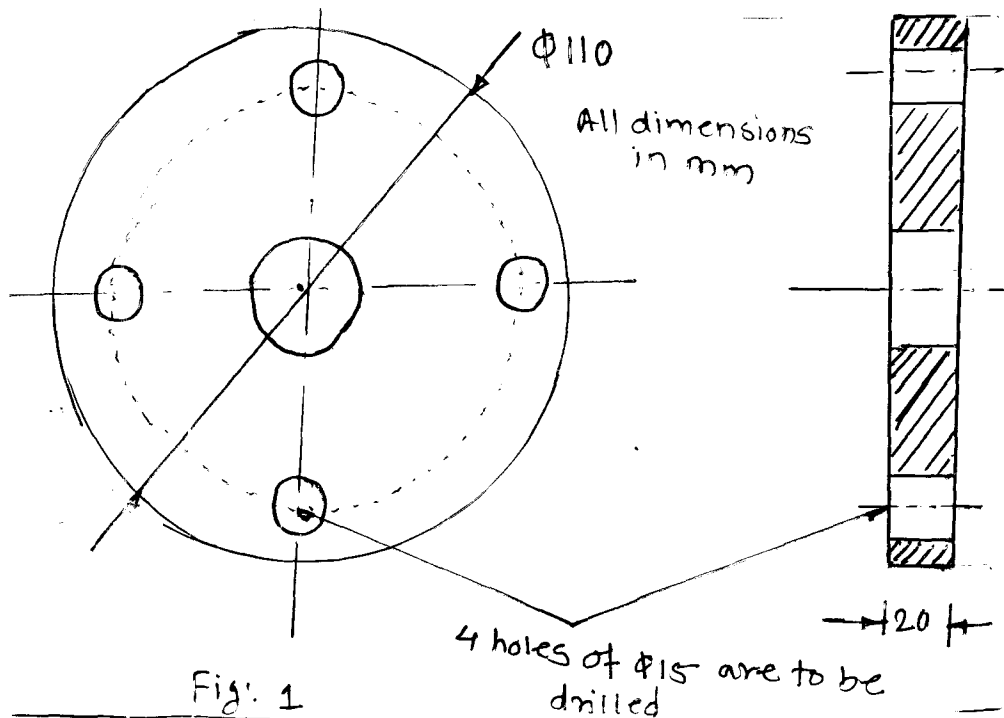

OR

- With the help of suitable diagram explain the following: (10)
- i) Redundancy in location.
 - ii) Foolproofing during location.
- Q.3** What is underlying principle of Laser beam machining? What type of work-piece is not suitable for this process? Give a schematic illustration of the laser beam machining process. (10)

OR

- Explain process principles and industrial applications of Ultrasonic machining. (10)
 What are the parameters which can affect the performance of USM?

P.T.O.

Q.4 What are the two typical configurations of DNC? List the various data and information that are transferred between the central computer and machine tools in DNC. (10)

OR

Three through holes of 17 mm diameter are to be drilled in a 11 mm thick steel plate as shown in fig.2. The left bottom corner (point A) of the pre-machined plate or any other suitable point may be taken as the reference point in XY plane. The program can be written in both absolute and incremental. (10)

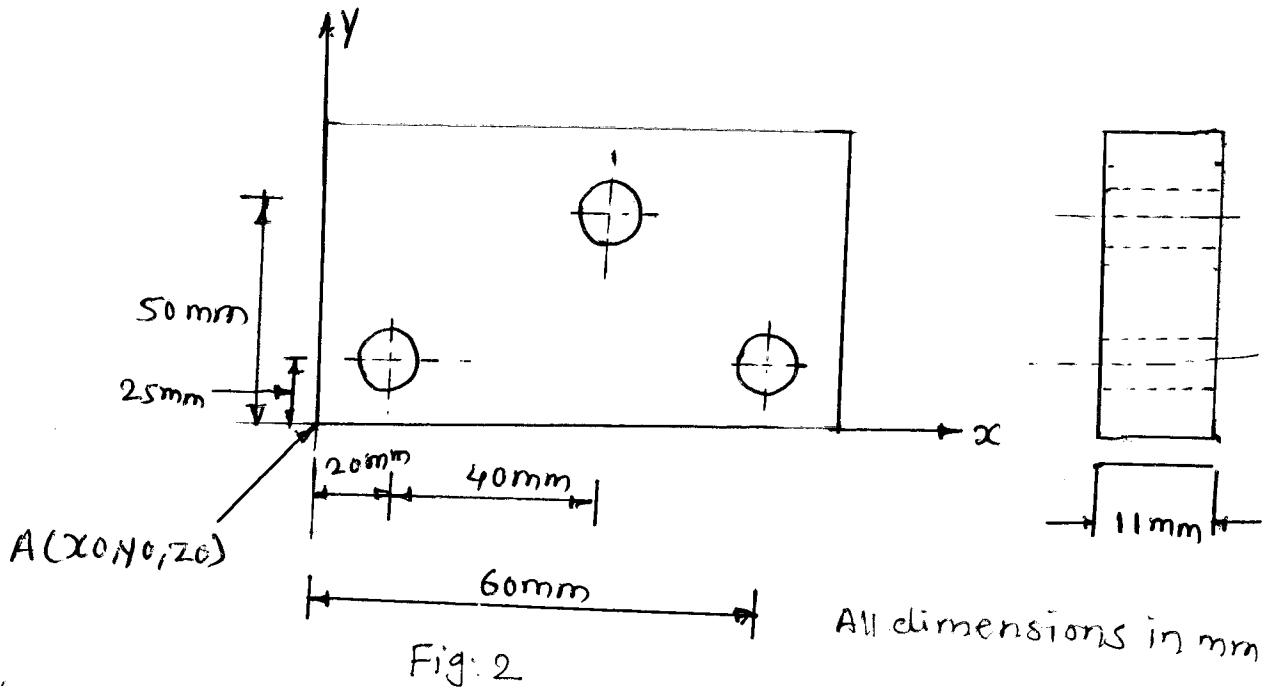

Q.5 Write down the advantages, limitations and purposes for following heat treatments, (10)
 i) Annealing ii) Hardening and Tempering iii) Carburizing

OR

Explain the principle of induction hardening as a surface hardening heat treatment cycle for HSS tool steel. (10)

Q.6 Explain any two methods for manufacturing of metal powders, Give its characteristics and applications (10)

OR

With neat sketch describe the manufacturing of composite. (10)

i) Putrusion process ii) Die molding process

* * * * *