

BACHELOR OF TECHNOLOGY (C.B.C.S.) (2014 COURSE)
B.Tech.Sem - VI PRODUCTION : : SUMMER - 2022
SUBJECT : JIG FIXTURE & DIE DESIGN

Day : Monday
Date : 13-06-2022

S-13476-2022

Time : 02:30 PM-06:30 PM
Max. Marks : 60

N.B.

- 1) All questions are **COMPULSORY**.
 - 2) Figures to the right indicate **FULL** marks.
-

Q.1 What is the need for locating a workpiece? How 3–2–1 principle of location fulfills the basic requirements of the location? (10)

OR

Q.1 What is need of quick action clamps in production tools? Sketch atleast four quick action clamps and discuss the merits and demerits of each. (10)

Q.2 What are the design considerations for drilling jig bushes? (10)

OR

Q.2 Explain with suitable sketch pump and sandwich jigs. (10)

Q.3 Design a milling fixture for the component shown in Fig. 1 for milling of a slot 6 mm wide. (10)

OR

Q.3 Design a milling fixture for use when machining the elongated flange of the elbow shown in fig. 2. This operation is done directly after drilling the four ϕ 10 mm holes. (10)

Q.4 Explain Blow Molding process and Transfer molding process with neat sketches. Also state its merits and demerits and application. (10)

OR

Q.4 a) What are the characteristics of thermosetting plastic? How do thermosetting plastics differ from thermoplastic? (05)

b) Describe compression Molding process in detail. (05)

Q.5 Draw injection moulding machine. Explain its construction, working. How injection moulding machines are specified? (10)

OR

Q.5 Design an injection moulding die for the components shown in fig. 3. Draw the assembly of the mould. (10)

Q.6 What are the challenges faced in die casting process? Why Al is the most preferred material? (10)

OR

Q.6 What are the considerations for design of pressure die casting dies? (10)

* * *

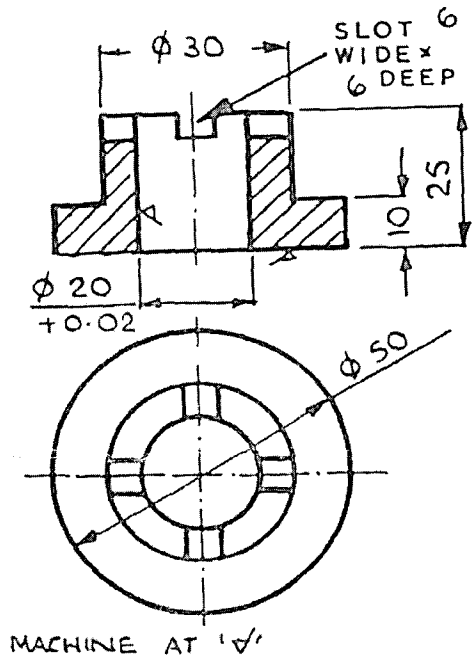

Fig. 1

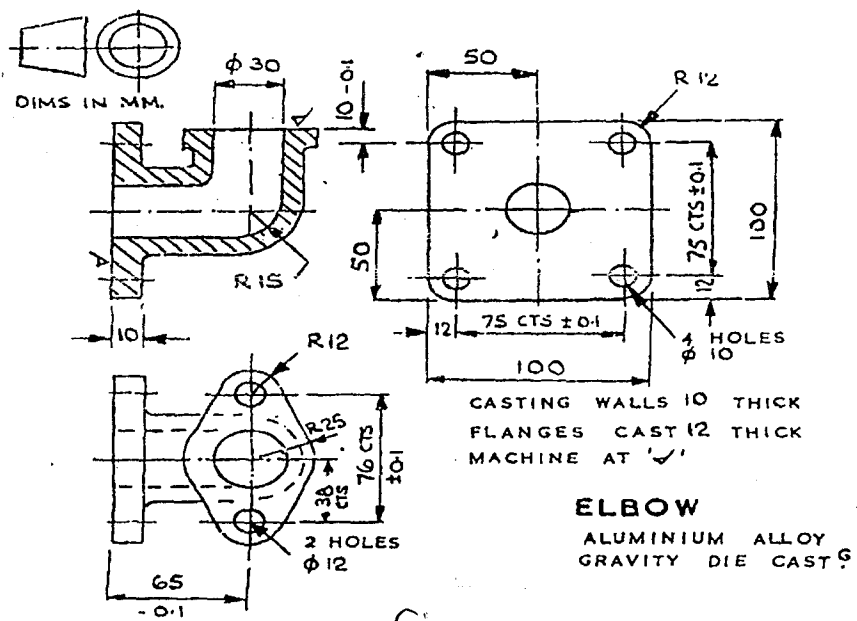

Fig. 2

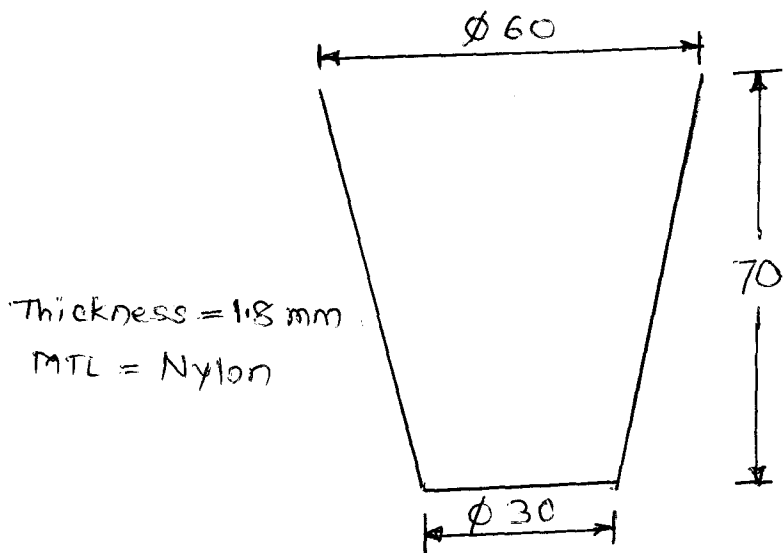

Fig. 3